



## OPERATION INSTRUCTION

**VRN-B**  
ULTRASONIC SCALER

## CONTENTS

<b>Components</b> .....	<b>2</b>
Copyright and Statement .....	<b>3</b>
<b>Warning</b> .....	<b>4</b>
<b>Installation and connection</b> .....	<b>5</b>
<b>Preparing for treatment</b> .....	<b>6</b>
<b>Manual for wrench</b> .....	<b>6</b>
<b>Setting the ultrasound power</b> .....	<b>7</b>
<b>Setting the liquid flow rate</b> .....	<b>8</b>
<b>Foot switch functions</b> .....	<b>9</b>
<b>End of treatment</b> .....	<b>9</b>
<b>Cleaning, disinfecting and sterilizing</b> .....	<b>10</b>
<b>Cleaning the unit</b> .....	<b>11</b>
<b>Disinfecting the circuit</b> .....	<b>11</b>
<b>Maintenance</b> .....	<b>12</b>
<b>Safety precautions</b> .....	<b>12</b>
<b>Storing the product</b> .....	<b>14</b>
<b>Disposal</b> .....	<b>14</b>
<b>Warranty</b> .....	<b>15</b>
<b>Accessories</b> .....	<b>15</b>
<b>VRN Service</b> .....	<b>16</b>
<b>Symbols</b> .....	<b>17</b>
<b>Technical data</b> .....	<b>18</b>
<b>Troubleshooting</b> .....	<b>19</b>
<b>EMC Declaration</b> .....	<b>24</b>

## COMPONENTS

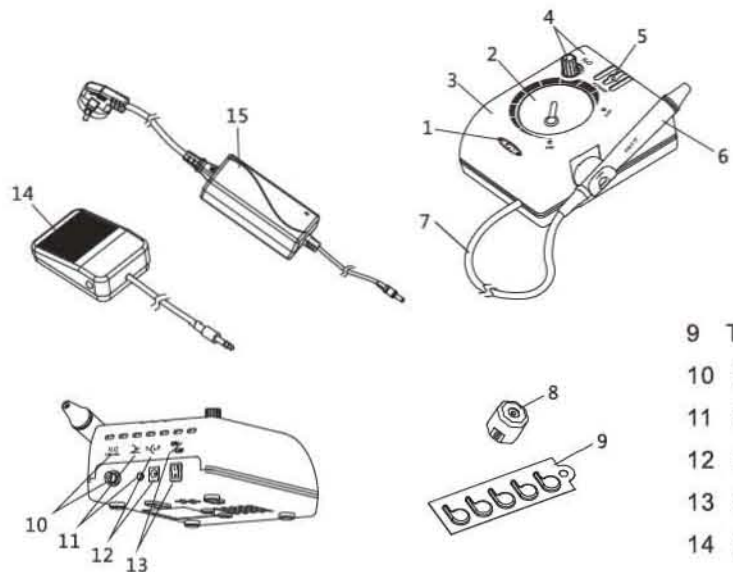

- 1 Model and LOGO
- 2 Vibration intensity knob and icon
- 3 Unit
- 4 Water volume knob and icon
- 5 Power LEDs
- 6 Sealed handpiece
- 7 Sealed cable
- 8 Tip wrench

- 9 Tips
- 10 Fluid circuit connection and icon
- 11 Foot switch connection and icon
- 12 External power supply connection and icon
- 13 Power switch and icon
- 14 Foot switch
- 15 External power supply

## Copyright and statement

Copyright © Guilin Veirun Medical Technology Co., Ltd.

Congratulations to become valued customers of Guilin Veirun Medical Technology Co., Ltd. Thanks for using K08B ultrasonic scaler. It will bring you the new experiences and conveniences.

This instruction manual is including the latest information when printing. Guilin Veirun Medical Technology Co., Ltd reserves the rights to change the design of the equipment, the technique, fittings the instruction manual and the content of original packing list at any time without notice. If there are some differences between blueprint and real product, take the real product as the norm.

This instruction manual is protected by copyright law. Without any official authorization, any form of duplication, copy or translated into another language is not allowed.

Read the instruction manual originally delivered with each of the components before using this product, and follow the instruction manual to operate. Otherwise, Guilin Veirun Medical Technology Co., Ltd does not take any responsibility for any errors and damage to the product because of violation operation.



**Note:** Gullin Veirun Medical Technology Co., Ltd does not promise any implied guarantee to the product special use for merchantability and applicability.

If you need after-sale service support, please contact with authorization dealer or manufacturer.

### Warning

The device is not suitable for use in the presence of flammable anesthetic mixtures with air or with oxygen or nitrous oxide.

The device requires no calibration.

The device is not repairable and contains no user serviceable parts.

No modification of this equipment is allowed. (3rd Edition)

The user must check that the equipment functions safely and see that it is in proper working condition before being used.

The manufacturer does not require such preventive inspections by other persons.

### INSTALLATION AND CONNECTION

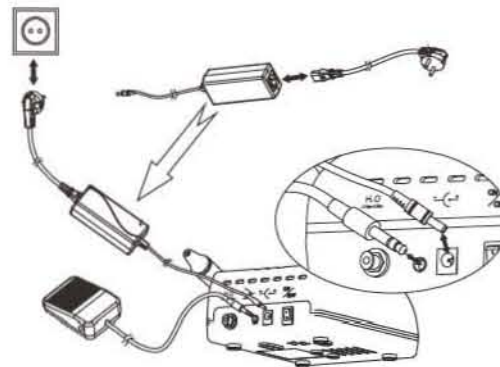

Always check that the unit is installed in a safe and stable position. An eventual fall may suddenly pull on the cord and the handpiece, hurting the patient and the user, and damaging the unit.

Check that the rated voltage of the power supply corresponds to the local line voltage to prevent damaging the unit.

Use the unit only in a FI protected mains supply (FI = Residual current protection).

For USA or Canada: connect only to an Hospital Grade outlet.

## PREPARING FOR TREATMENT



Clean, disinfect and sterilize the different pieces and accessories of this product before each use. Please refer to the information provided in the operating instructions. Non-sterile pieces and accessories may cause bacterial or viral infections.

## MANUAL FOR WRENCH



With a special structure design, wrench makes sure that users can handling the tip effectively during Using it, and protects user's hand from hurting in the process of loading and unloading the tip.  
Sterile environment: Temperature 135 degrees, Pressure 0.22Mpa, in the steam.

Steps:

- (1) Align the legs of the wrench to the tip.
- (2) Install the tip: grip the handle, rotate the tip in right-handwise till the tip dose not turn round anymore.
- (3) Unloading the tip: grip handle then rotate the tip in counter-clockwise by wrench to remove it.
- (4) Once after using, please put the wrench into disinfection cabinet to disinfect.
- (5) After disinfection, the surface temperature of the wrench is too high to be used again, so users must wait until it is cool down, avoiding hurt.
- (6) When not use the wrench, put it at some place that is dry and ventilated, and keep it clean.

## SETTING THE ULTRASOUND POWER

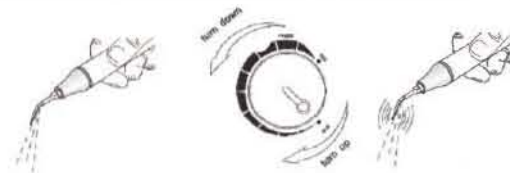

Using the vibration intensity knob increases or decreases the power of the ultrasound. Adjust vibration intensity on-demand, generally, the medium is right, it also can be adjusted in the clinical course according to the sensitivity of patients and the hardness of the dental stone.

⚠ Adjust power to the lowest when just turn on the host.

### SETTING THE LIQUID FLOW RATE



Depress the foot switch, and the tip starts vibrating, and then revolve the water volume knob and the water spraying puffs, it will cool down the handle and clean the surface of teeth.

Never work dry to avoid heat damage on the tooth. The tip of the instrument immediately heats up when used dry.

⚠ Adjust water volume to larger when just turn on the host.

### FOOT SWITCH FUNCTIONS



### END OF TREATMENT

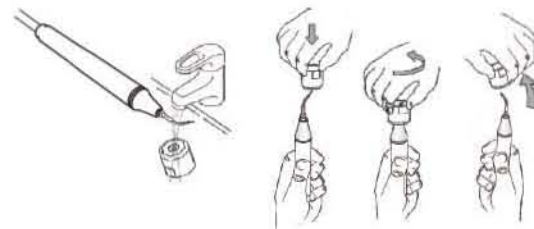

Clean the instrument with running water before disinfection.

Please conform to the recommendations of the "Reprocessing Instructions" manual delivered with your product regarding the procedures of cleaning, disinfecting and sterilizing of the components.

## CLEANING, DISINFECTING AND STERILIZING

### Handpiece and disinfection

Select disinfectant to wipe and cleaning. Such as iodine or alcohol or glutaraldehyde disinfectant and so on.

#### Notices

- (1) Remove the tip after working every time.
- (2) Be sure to remove the tip from the handpiece before disinfecting, and avoid mixing it together with other equipment.
- (3) In the process of using and disinfection, please feel free to pay attention that the handpiece is with external damages or not. Prohibit from applying and protected oil on the surface of the handpiece.
- (4) Prohibit to soak the handpiece into disinfectant, for example iodine, alcohol, glutaraldehyde and so on.

### Tip Sterilization

The tips can be sterilized by alcohol or disinfectant wipes, it can also be sterilized by HTY.

### Wrench Sterilization

It can be sterilized by any neutral disinfectant without any corrosivity and HYT.

### Wrench and tips Cleaning

The wrench and tips can be cleaned in the ultrasonic cleaner.

#### Notices

Prohibit to disinfect in the following ways:

- \* Put the wrench into boiling solution
- \* Soak the wrench and tips into disinfectant, for example iodine, alcohol, glutaraldehyde and so on.
- \* Put the wrench and tips into oven or microwave to bake in high-temperature.



Follow present-day regulations enforced in the country about reprocessing.

## CLEANING THE UNIT



Clean the unit only with an alcohol-based, commercially-available, colorless disinfectant (ethanol, isopropanol). The use of scouring powder or an abrasive sponge will damage its surface. The unit is not protected against water spray. It cannot be sterilized.

## DISINFECTING THE CIRCUIT



It is recommended to disinfect the liquid circuit daily.

Disinfection is necessary to reduce crystalline deposits and the number of bacteria in the liquid circuit of the unit; The following procedure achieves a 4 log reduction of target pathogens :

1. Make sure the water you are using is distilled (or dematerialized) water.
2. Remove the handpiece. Revolve the water volume knob to the max point.
3. Turn on the scaler and depress the foot switch.
4. Allow the disinfecting water to rinse the circuit for 3 to 5 minutes.

## MAINTENANCE



Always use VRN original parts. Using non-original instruments may damage the unit, and practitioner or patient may be injured.

## SAFETY PRECAUTIONS

VRN and the dealer of this product accept no liability for direct or consequential injury or damage resulting from improper use, arising in particular through non-observance of the operating instructions, or improper preparation and maintenance.



Contraindication: ultrasonic oscillations may prevent cardiac pace makers and defibrillators from functioning properly. Therefore, we recommend that patients with a cardiac pace maker or a defibrillator should not be treated with this product.

Use for the intended purpose only: before using the product, make sure that you have studied the operating instructions. This also applies to any equipment used with this product. Failure to observe the operating instructions may result in the patient or user suffering serious injury or the product.

Risk of explosion: do not use this product in the presence of inflammable anaesthetics or gases. This product must be used only by trained and qualified personnel.

Clean, disinfect and sterilize the different pieces and accessories of this product before each use. Please refer to the information provided in the operating instructions. Non-sterile pieces and accessories may cause bacterial or viral infections.

This product has been investigated with regard to safety from electrical shock and fire hazard. ETL (Electrical Testing Laboratories) has not investigated the physiological effects.

Always examine the product for damage before commencing treatment. Damaged accessories or a damaged unit must not be used and must be replaced. Use original VRN spare parts and accessories only.



Have this product exclusively repaired by an approved VRN repair center.  
Use exclusively the external power supply delivered with the VRN unit.

Certain types of mobile telecommunication equipment could potentially interfere with this product. The separation distances recommended in the "Electromagnetic compatibility" manual must be taken into account.

## STORING THE PRODUCT

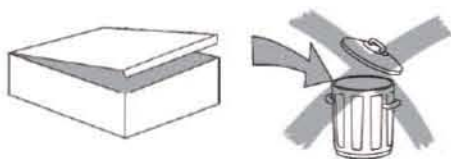

Keep the original packaging until the product is to be disposed of permanently. It can be used for shipping or storing at any time.

Should you wish to put your product out of use for an extended period of time:

- Proceed as described in the "Cleaning, disinfecting and sterilizing" chapter,
- Pack the product and all accessories in the original packaging.

Please refer to the storage and transport conditions in the "Technical data" chapter.

## DISPOSAL

The product must not be discarded in domestic household waste.

Should you wish to definitively dispose of the product, please comply with the regulations which apply in your country.

Waste Electrical and Electronic Equipment belonging to customers located in the European Union may be shipped to VRN for recycling in accordance to the WEEE regulations. The costs of recycling, exclusive of shipping fees, are covered by VRN.

## WARRANTY

Damages due to non-adherence to the operating instructions or wear out of parts are excluded from warranty.



The warranty of your product will be cancelled if you try to open it.

## ACCESSORIES

Accessories are available from VRN or any authorized dealers. Please contact your customer service directly.

## VRN SERVICE

Should your product need additional servicing or repairs, please send it to your dealer or to an authorized VRN Repair Center.

In the case of non-authorized repairs or damages due to non-adherence to the operating instructions, VRN accepts no liability whatsoever. This will also void the warranty.





















It is best to ship your product in the original packaging. It protects your product against damage during shipment.

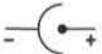

Risk of transmitting micro-organisms! To protect the personnel of the repair center and for safety reasons during transport and shipment, the product and the accessories returned to the factory for repair or revision must be cleaned, disinfected and sterilized in accordance with the operating manual. Repair can be refused for

When sending your product directly to the approved VRN repair center, please include the name of your dealer. This simplifies processing.

## SYMBOLS

	Manufacturer's logo		Caution! Read the operation instruction		Class II equipment		Applied part, type BF
	Disposal		Manufacturer		Used indoor only		Serial number
	Autoclavable		Storage Humidity		Storage Temp		Keep dry
	Fragile		Refer to instruction manual / booklet		Authorised representative in the European community		CE marking: refers to directive 93/42 EEC, including EN60601-1 and EN60601-1-2
	Electrical Outlet		Foot switch connection		Water supply		Power Switch

## TECHNICAL DATA

Description	Manufacturer Guilin Veirun Medical Technology Co., Ltd.
Models	K08B
Classification EN 60601-1	- Class II - Applied part, Type BF - IP 20, unit - IP X1, foot pedal
	Not category AP/APG equipment
Classification 93 / 42 EEC	Class IIa
Operating mode	Continuous operation
Power Supply	
Adaptor Input	100-240 VAC / 50-60 Hz, 1.3A
Adaptor Output	30VDC
Power consumption	30VA~48 VA
External power supply	45W 30V 2m R5.5- 2.5+
Ultrasonic specifications:	
Maximum output	8 Watts
Frequency range	25-31kHz
Weight	Approx. 1.45Kg
Dimensions in mm (HxWxD)	75 x 150 x 160
Operating conditions	+10 °C to +40 °C 30% to 75% relative humidity
Storage and transport conditions	-10 °C to +40 °C 10% to 95% relative humidity 500 hPa to 1 060 hPa air pressure

## TROUBLESHOOTING

Fault	Possible cause	Solutions
The scaling tip doesn't vibrate and there is no water flowing out when stepping on the foot Switch	The power plug is in loose contact	Make the plug insert to the socket well
	The foot pedal is in loose contact ( wire foot Switch)	Insert the foot switch to its socket tightly
	The fuse in the main unit is broken	Contact the dealers or us
	The battery for wireless control foot Switch died	Change the new batteries
The scaling tip does not vibrate but there is water flowing out when stepping on the foot Switch	The tip is in loose contact	Screw the tip on the handpiece tightly
	The connect plug between the handpiece and the circuit board is in loose contact	Contact the dealer or us
	Handpiece problem	Send the handpiece to dealer or us to repair
	Cable problem	Contact the dealer or us
The scaling tip vibrates but there is no spray when stepping on the foot Switch	The water control knob is not on	Turn on the water control knob [note 1]
	There is impurity in the electric-magnetic valve	Take the electric-magnetic valve apart or contact the dealer or us
	The water system is blocked	Clean the water pipe by multi-function syringe [note 2]
There is still water flowing out after the power is off	The electric-magnetic valve problem	Contact the dealer or us
The handpiece generates heat	The water control knob is in a low setting	Turn the water control knob to a higher grade [note 1]

Fault	Possible cause	Solutions
The amount of spouting water is too little	The water control knob is in a low setting	Turn the water control knob to a higher grade 【note 1】
	The water pressure is not high enough	Make the water pressure higher
	The water system is blocked	Clean the water pipe by multi-function syringe 【note 2】
The vibration of the tip becomes weak	The tip has not been screwed on to the handpiece tightly	Screw the tip tightly
	The coupling between the handpiece and the cable is not dry	Dry it by the hot air
	The tip is damaged 【note 3】	Change the new scaling tip
There is water leaking from the coupling between the handpiece and the cable	The waterproof <b>O-ring</b> is damaged	Change the new waterproof <b>O-ring</b>
The U-file does not vibrate	The screw is loose	Tighten it
	Endochuck is damaged	Change the new endochuck
There is noise coming from the endochuck	The screw is loose	Tighten it



**Notice:**

**If the problem still cannot be solved, please contact with local dealer or manufacturer.**



**Notes**

【note 1】

Turn the water control knob as symbol showed. It comes to the min, on the contrary direction, it comes to the max.

【note 2】

1)Clean the water pipe with the multi-function syringe of the dental unit ;

2)Disconnect the water pipe from main unit;

3)Get through to the power and turn on the power switch;

4)Connect the multi-function syringe of dental unit to the water pipe;

5)Disassemble the tip or handpiece;

6)Step on the foot switch;

7)Turn on the switch of the multi-function syringe, press the water into the machine and the impurity blocked in the water pipe can be eliminated.

【note 3】 If the scaling tip has been screwed on tightly and there is fine spray too, the following phenomena

show that the scaling tip is damaged:

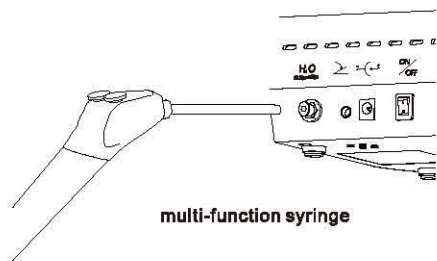

## TROUBLESHOOTING FOR THE ELECTRIC-MAGNETIC VALVE

If the water is not clean or the electric-magnetic valve works too long, there will be the scale and impurity generated on the inside wall and valve plug. It will cause the water way to be blocked, and could repair as following steps:

1 ) Follow the [ note 2 ]

2 ) Uninstall the electric-magnetic valve by following steps:

a) Turn off the power, and unplug the power cable;

b) Unscrew the cap, and move out the hood of main unit;

c) Unscrew the cap on the electric-magnetic valve, and Uninstall the electric-magnetic valve as shown on

Figure ;

d) Take out the valve plug, and clean out the impurity on the inside wall;

e) Install the parts as shown on the figure .

f) Ensure the water way is working by repeat [ note 2 ]

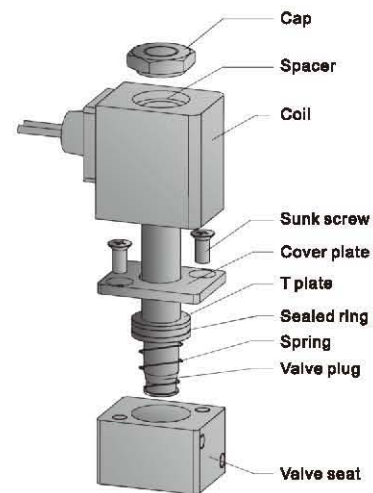

## EMC DECLARATION

Table 1

Guidance and manufacturer's declaration - electromagnetic emissions		
The [K08] is intended for use in the electromagnetic environment specified below. The customer or the user of the [K08] should assure that it is used in such an environment		
Emissions test	Compliance	Electromagnetic environment - guidance
RF emissions CISPR 11	Group 1	The [K08] uses RF energy only for its internal function. Therefore, its RF emissions are very low and are not likely to cause any interference in nearby electronic equipment.
RF emissions CISPR 11	Class [B]	The [K08] is suitable for use in all establishments other than domestic, and may be used in domestic establishments and those directly connected to the public low-voltage power supply network that supplies buildings used for domestic purposes, provided the following warning is heeded: <b>Warning:</b> This equipment/system is intended for use by healthcare professionals only. This equipment/ system may cause radio interference or may disrupt the operation of nearby equipment. It may be necessary to take mitigation measures, such as re-orienting or relocating the [K08] or shielding the location.
Harmonic emissions IEC 61000-3-2	Class A	
Voltage fluctuations/ flicker emissions IEC 61000-3-3	Complies	

Table 2

Guidance and manufacturer's declaration - electromagnetic emissions			
The [K08] is intended for use in the electromagnetic environment specified below. The customer or the user of the [K08] should assure that it is used in such an environment			
Immunity Test	IEC 60601 Test level	Compliance level	Electromagnetic environment - guidance
Electrostatic discharge (ESD) IEC 61000-4-2	±6 kV contact ±8 kV air	±6 kV contact ±8 kV air	Floors should be wood, concrete or ceramic tile. If floors are covered with synthetic material, the relative humidity should be at least 30 %
Electrical fast transient/burst IEC 61000-4-4	±2 kV for power supply lines ±1 kV for input/output lines	±2 kV for power supply lines ±1 kV for input/output lines	Mains power quality should be that of a typical commercial or hospital environment.
Surge IEC 61000-4-5	±1 kV line(s) to line(s) ±2 kV line(s) to earth	±1 kV line(s) to line(s) ±2 kV line(s) to earth	Mains power quality should be that of a typical commercial or hospital environment.

Voltage dips, short interruptions and voltage variations on power supply input lines IEC 61000-4-11	<5% U <sub>T</sub> (>95% dip in U <sub>T</sub> ) for 0.5 cycle	<5% U <sub>T</sub> (>95% dip in U <sub>T</sub> ) for 0.5 cycle	Mains power quality should be that of a typical commercial or hospital environment. If the user of the [K08] requires continued operation during power mains interruptions, it is recommended the [K08] be powered from an uninterruptible power supply or a battery.
	40% U <sub>T</sub> (60% dip in U <sub>T</sub> ) for 5 cycle	40% U <sub>T</sub> (60% dip in U <sub>T</sub> ) for 5 cycle	
70% U <sub>T</sub> (30% dip in U <sub>T</sub> ) for 25 cycle	70% U <sub>T</sub> (30% dip in U <sub>T</sub> ) for 25 cycle		
	<5% U <sub>T</sub> (>95% dip in U <sub>T</sub> ) for 5s	<5% U <sub>T</sub> (>95% dip in U <sub>T</sub> ) for 5s	
Power frequency (50/60Hz) magnetic field IEC 61000-4-8	3 A/m	3 A/m	Power frequency magnetic fields should be at levels characteristic of a typical location in a typical commercial or hospital environment.
NOTE U <sub>T</sub> is the a.c. mains voltage prior to application of the test level.			

Table3

Guidance and manufacturer's declaration - electromagnetic emissions			
The [K08] is intended for use in the electromagnetic environment specified below. The customer or the user of the [K08] should assure that it is used in such an environment			
Immunity Test	IEC 60601 Test level	Compliance level	Electromagnetic environment - guidance
Conducted RF IEC 61000-4-6	3Vrms 150KHz to 80MHz	3V	<p>Portable and mobile RF communications equipment should be used no closer to any part of the [K08], including cables, than the recommended separation distance calculated from the equation applicable to the frequency of the transmitter.</p> <p><b>Recommended separation distance</b></p> $d = 1,2\sqrt{P}$
Radiated RF IEC 61000-4-3	3 V/m 80MHz to 2.5GHz	3 V/m	$d = 1,2\sqrt{P} \quad 80 \text{ MHz to } 800 \text{ MHz}$ $d = 2,3\sqrt{P} \quad 800 \text{ MHz to } 2,5 \text{ GHz}$ <p>where <math>p</math> is the maximum output power rating of the transmitter in watts (W) according to the transmitter manufacturer and <math>d</math> is the recommended separation distance in metres (m)</p> <p>Field strengths from fixed RF transmitters, as determined by</p>

			<p>an electromagnetic site survey,<sup>a</sup> should be less than the compliance level in each frequency range.<sup>b</sup></p> <p>Interference may occur in the vicinity of equipment marked with the following symbol:</p> 
<p>NOTE 1 At 80 MHz and 800 MHz, the higher frequency range applies.</p> <p>NOTE 2 These guidelines may not apply in all situations. Electromagnetic propagation is affected by absorption and reflection from structures, objects and people.</p>			
<p><sup>a</sup> Field strengths from fixed transmitters, such as base stations for radio (cellular/cordless) telephones and land mobile radios, amateur radio, AM and FM radio broadcast and TV broadcast cannot be predicted theoretically with accuracy. To assess the electromagnetic environment due to fixed RF transmitters, an electromagnetic site survey should be considered. If the measured field strength in the location in which the [K08] is used exceeds the applicable RF compliance level above, the [K08] should be observed to verify normal operation. If abnormal performance is observed, additional measures may be necessary, such as re-orienting or relocating the [K08].</p> <p><sup>b</sup> Over the frequency range 150 kHz to 80 MHz, field strengths should be less than 3 V/m.</p>			

Table 4

Recommended separation distances between portable and mobile RF communications equipment and the [K08]			
<p>The [K08] is intended for use in an electromagnetic environment in which radiated RF disturbances are controlled. The customer or the user of the [K08] can help prevent electromagnetic interference by maintaining a minimum distance between portable and mobile RF communications equipment (transmitters) and the [K08] as recommended below, according to the maximum output power of the communications equipment.</p>			
Rated maximum output power of transmitter W	Separation distance according to frequency of transmitter m		
	150 kHz to 80 MHz $d = 1,2\sqrt{P}$	80MHz to 800MHz $d = 1,2\sqrt{P}$	800MHz to 2.5GHz $d = 2,3\sqrt{P}$
0,01	0.12	0.12	0.23
0,1	0.38	0.38	0.73
1	1.2	1.2	2.3
10	3.8	3.8	7.3
100	12	12	23
<p>For transmitters rated at a maximum output power not listed above, the recommended separation distance <math>d</math> in metres (m) can be estimated using the equation applicable to the frequency of the transmitter, where <math>P</math> is the maximum output power rating of the transmitter in watts (W) according to the transmitter manufacturer.</p> <p>NOTE 1 At 80 MHz and 800 MHz, the separation distance for the higher frequency range applies.</p> <p>NOTE 2 These guidelines may not apply in all situations. Electromagnetic propagation is affected by absorption and reflection from structures, objects and people.</p>			

